

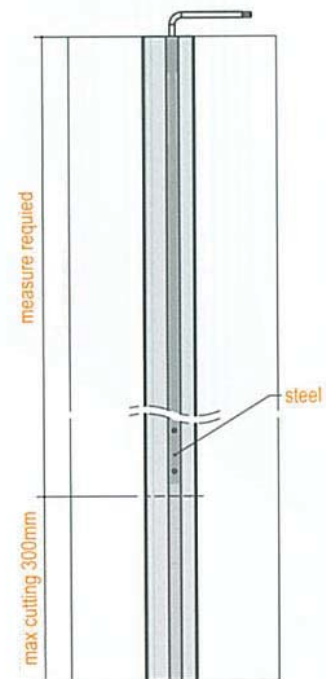

# Aluminium wardrobe adjuster type ST761

The tensioner make the first and second ring a single body through gluing ensuring flatness.  
No screws.  
Excellent aesthetic appearance.  
Fully recessed, it helps packaging or panel in process.

Fixing by gluing ribbed finish.  
Linear density 840g/m  
Length : 2500mm  
          : 3000mm

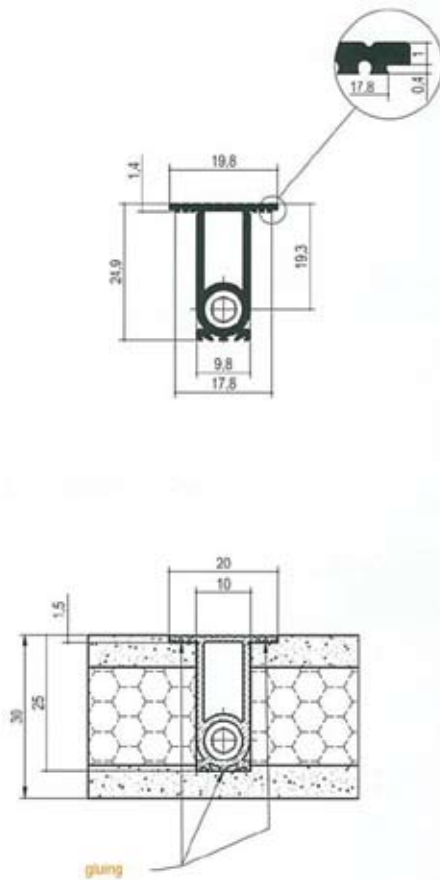
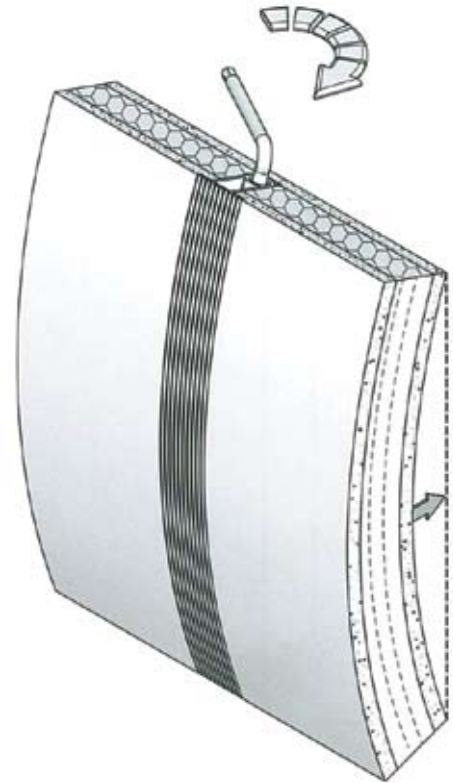

Cutting procedures only in the lower part.  
The cut can be done with blade for wood or aluminium .  
Maximum cutting 300mm.